

Rinnai

'HOTFLO'[®] Operation / Installation Manual Mains Pressure Vitreous Enamel Electric Storage Water Heater



Installation and Service must be performed by an authorised person.

THIS APPLIANCE IS NOT SUITABLE FOR USE AS A POOL OR SPA HEATER.

This appliance shall be installed in accordance with:

- Manufacturers Installation Instructions
- Municipal Building Codes
- AS/NZS 3000 Wiring Rules
- AS/NZS 3500.4 Plumbing and Drainage
- Any other local relevant Statutory Regulation

Certified
Product



WaterMark
AS3498 Lic W20067
SAI Global



N10378

Quality System
Quality
Endorsed
Company
ISO 9001 Lic 4983
SAI Global
Head Office Certified

Distributed and serviced in Australia under a Quality System certified as complying with ISO 9001 by SAI Global

REGULATORY INFORMATION

Your Rinnai Hotflo Mains Pressure Vitreous Enamel Storage Electric Water Heater has been certified by relevant plumbing and electrical authorities and the details are shown on data plate.

This appliance must be installed correctly by an authorised person and must conform to location regulations.

The installation must also comply with the instructions supplied by Rinnai.

Please keep this instruction booklet in a safe place for future reference.

Notice to Victorian Consumers

This appliance must be installed by a person licensed with the Plumbing Industry Commission.

Only a licensed person will have insurance protecting their workmanship.

So make sure you use a licensed person to install this appliance and ask for your Compliance Certificate.

For further information contact the Plumbing Industry Commission on 1800 015 129.

WARNINGS

Installation and service only by an authorised person.

- **DO NOT** operate this system before reading the manufacturers instructions
- **DO NOT** place articles on or against this appliance
- **DO NOT** store chemicals or flammable materials near this appliance
- **DO NOT** operate with panels or covers removed from this appliance
- **DO NOT** activate heating elements unless cylinder is full of water
- **DO NOT** touch any power supply cords, plugs or electrical conduits with wet hands.

Removal of access covers will expose 240V wiring. Access covers to be removed by authorised persons only.

This water heater is not intended to be operated or adjusted by young children or infirm persons. Young children must be supervised to ensure they do not interfere with the water heater.

If the power supply cord, plug or electrical conduit to the water heater is damaged, it must be replaced by an authorised person in order to avoid a hazard, using genuine replacement parts available from Rinnai.

TABLE OF CONTENTS

REGULATORY INFORMATION	i
WARNINGS	i
SAFETY	4
Hydrogen Gas.....	4
Water Temperature.....	4
IMPORTANT INFORMATION	4
SAFETY DEVICES	5
ANODE	5
WATER QUALITY.....	5
TURNING 'OFF' THE WATER HEATING SYSTEM.....	5
TURNING 'ON' THE WATER HEATING SYSTEM.....	5
HOW THE WATER HEATER WORKS	5
REGULAR CARE.....	6
Over flow tray and drain.....	6
Pressure and Temperature Relief (P&TR) Valve.....	6
Expansion Control Valve (ECV) if fitted	6
SERVICING AND REPAIR	7
SAVE A SERVICE CALL	7
LACK OF HOT WATER OR NO HOT WATER	7
HIGH ELECTRICITY BILLS.....	7
WATER HEATER VALVES DISCHARGING EXCESSIVELY	8
GENERAL INSTALLATION	9
INSTALLATION DIAGRAMS.....	9
Figure 1 - Typical Installation of Water Heater	9
Figure 2 - Hot Water Plumbing System Example - No Temperature Limiting Device	9
Figure 3 - Hot Water Plumbing System Example - with Temperature Limiting Device (TLD)	10
Figure 4 - Hot Water Plumbing Water Heater system Example - with Flow & Return Pipe Work ..	10
Figure 5 - Hot Water Plumbing System Example with Flow and Return Pipe Work and TLD	11
WATER HEATER LOCATION.....	11
WATER QUALITY.....	12
Connection to a low pressure gravity or tank water supply.....	12
HOT WATER STORAGE AND DELIVERY TEMPERATURES.....	12
Storage Temperature.....	12
Sanitary Fixtures Delivery Temperature	12
Water Pipes	12
Electrical Supply	13
Valves and fittings.....	13

CUSTOMER INFORMATION

PLUMBING CONNECTIONS	13
P&TR Valve Connection	13
Expansion Control Valve (ECV).....	14
Drain Lines	14
ELECTRICAL CONNECTIONS	14
Figure 6 - Single Element Wiring Diagram	14
Thermostat Setting.....	14
COMMISSIONING	15
To fill and turn 'ON' the water heater	15
To turn 'OFF' the water heater	15
Draining.....	15
SPECIFICATIONS	16
Figure 7 - Dimensional Drawing	16
Table 1 - Specifications	17
Table 2 - Warranty Terms	18
Definition of Domestic Use.....	18
Definition of Commercial Use	18
WARRANTY	18
WARRANTY CONDITIONS.....	19
Table 3 - Water chemistry and impurity limits for all water heating systems	19
WARRANTY EXCLUSIONS	19
CONTACT INFORMATION	21

SAFETY

Hydrogen Gas

If the hot water heater is not used for two weeks or more, a quantity of hydrogen gas, which is highly flammable, may accumulate in the water heater. To dissipate this safety, it is recommended that a non electrically operated hot tap be turned on for several minutes at a sink, or bath, but not at dishwasher or other appliance. During this procedure there must be no smoking, open flame or any electrical appliance operating nearby. If hydrogen gas is discharged through the tap, it will probably make a sound like air escaping.

Water Temperature

To meet regulatory requirements the temperature of stored water heater must not be less than 60°C. The thermostat on your water heater is factory pre-set to 65°C which is suitable for the vast majority of domestic applications.

The thermostat setting can be adjusted between 60°C and 75°C by an electrician or other suitably qualified trades person.



- The thermostat setting must only be adjusted by an Electrician or other suitably qualified trades person.
- The access cover to the element and thermostat must only be removed by an Electrician or other suitably qualified trades person.

IMPORTANT INFORMATION



DANGER BEWARE OF SCALDING HAZARDS

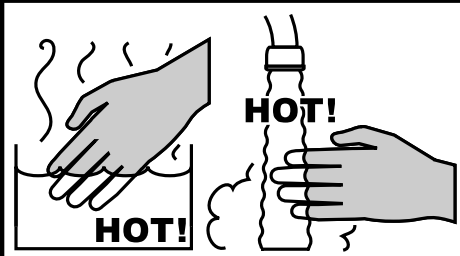

Hot Water can cause scalds.

Children, disabled, and the elderly are at the highest risk of being scalded.

Feel water temperature before bathing or showering.

Scalds from hot water taps can result in severe injuries to young children.

Scalds can occur when children are exposed directly to hot water when they are placed into a bath which is too hot.

DO

- Do stay with children whenever they are in the bathroom (Take the phone off the hook).
- Do take them out of the bathroom if you need to answer the phone or door.
- Do test the temperature of the water with your elbow before placing your child in the bath.
- Do make sure that the tap is turned off tightly.
- Do install a child proof tap cover OR
- Do install a child resistant tap.
- Consider child-resistant taps or tap covers, which prevent a small hand being able to turn on the tap.
- Consider installing tempering valves or thermostatic mixing valves which reduce the hot water temperature delivered to taps. Your local plumbing authority may already require that these be fitted. Contact your installer or local plumbing authority if in doubt.

DON'T

- DON'T leave a toddler in the care of another small child. The older child may not have set the water temperature to a safe level.

IMPORTANT INFORMATION

SAFETY DEVICES

For safe operation this water heater is fitted with a combination Pressure & Temperature Relief (P&TR) Valve, a thermostat and an over-temperature cutout for each heating element.



- **DO NOT** tamper with or remove safety devices.
- **DO NOT** operate this water heater unless all safety devices are fitted and in working order.
- **DO NOT** block or seal the P&TR Valve and drain pipe.

ANODE

The water heater is fitted with a sacrificial anode to extend its life. It will slowly dissipate whilst protecting the cylinder. The life of the water heater may be extended by arranging for an authorised person to inspect the anode and replace it if required. It is recommended that the anode be inspected at least every 5 years.

WATER QUALITY

The water quality of most public supplies is suitable for the water heating system. The water quality from bore wells is generally unsuitable for the water heating system. Refer to the 'Warranty Conditions' for water quality parameters and how they affect the warranty conditions. If in doubt about the water quality, have it checked against the parameters listed in the warranty conditions.

If sludge or foreign matter is present in the water supply, a suitable strainer filter should be incorporated in the water supply to the system.

TURNING 'OFF' THE WATER HEATING SYSTEM

If you plan to be away for only a few nights, we suggest you leave the water heating system switched on. If it is necessary to switch off the water heater, the switch is usually marked and located in the electricity meter box of the dwelling.

TURNING 'ON' THE WATER HEATING SYSTEM

Switch on the electric supply to the heating element. The switch is usually marked and located in the electricity meter box of the dwelling. Water heating will now occur as required. It may take a number of hours before hot water is available.

HOW THE WATER HEATER WORKS

A vitreous enamel lined steel cylinder stores water which is heated by an electric heating element located at the base of the cylinder. An automatic thermostat controls the water temperature. The water heater connects directly to the mains water supply.

The heating element can be connected to a Continuous or Off-Peak electricity supply. The continuous supply is appropriate when the water heater capacity is less than the daily usage of hot water. The Off-Peak supply is appropriate when the water heater capacity exceeds the daily usage of hot water. The Off-Peak supply allows heating only for set periods and a volume of water sufficient for daily usage is heated during the set period and stored. The Off-Peak supply is usually cheaper. Electricity supply types and tariffs vary according to the local electricity authority.

IMPORTANT INFORMATION

REGULAR CARE

Over flow tray and drain

The overflow tray and drain (if fitted) should be periodically checked to ensure there are no blockages.

Pressure and Temperature Relief (P&TR) Valve

This valve is located near the top of the water heater and is essential for safe operation. It is normal for the valve to release a small quantity of water through the drain line during heating. However, continuous leakage of water from the valve and its drain line may indicate a problem with the water heater.



- **Never block the outlet of the P&TR valve or its drain line for any reason. The easing gear must be operated at least once every six months or more frequently in areas with a high incidence of water deposits. It is very important you raise and lower the easing gear gently.**
- **Failure to do this may result in the water heater cylinder failing or under certain circumstances, exploding.**



- **If the valve does not discharge water when the easing gear lever is lifted, or does not seal again when the easing gear is closed, attendance by an authorised person must be arranged without delay. The P&TR valve is not serviceable.**

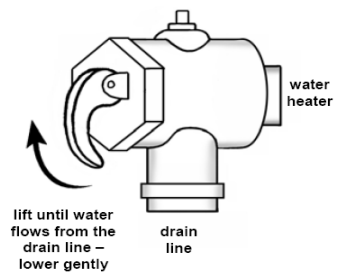

Expansion Control Valve (ECV) if fitted

Operate the easing lever on the expansion control valve once every six months. It is very important you raise and lower the lever gently.

SERVICING AND REPAIR

Our Servicing network personnel are fully trained and equipped to give the best service on your Rinnai appliance. If your appliance needs service, ring one of the service contact numbers on the back of this booklet.

The pressure and temperature relief valve and expansion control valve must be checked for performance or replaced by an authorised person at intervals not exceeding 5 years or more frequently in areas where the water is classified as scaling water (see 'Water Quality').

It is recommended that the sacrificial anode be inspected every 5 years or more frequently in areas where there is a high incidence of water deposits.

If the electric conduit, power supply cord or plug to the water heater is damaged, they must be replaced by an authorised person in order to avoid a hazard. The power supply cord and plug (if fitted) must be replaced by a genuine replacement part available from Rinnai.

SAVE A SERVICE CALL

Check the items below before requesting Service. Service and parts charges may be incurred where it is found that there is no fault with the water heater and the issue is related to the plumbing installation or is due to the failure of water or electric supplies.

LACK OF HOT WATER OR NO HOT WATER



Is there electricity supply to the water heater?

- Check that the isolating switch marked "HOT WATER" or "WATER HEATER" at the meter box is switched on. Check also that any isolating switches installed near the water heater are switched on.
- Check the fuse or circuit breaker marked "HOT WATER" or "WATER HEATER" at the meter box. Repeated failure of fuse or tripping of circuit breaker indicates a fault which must be investigated by an authorised trades person.



Are you using more hot water than you think?

- Often it is not realized how much hot water is actually used. This applies especially to showering. Review hot water usage, especially the time taken for showering, and investigate the use of flow control valves or Water saving shower roses.



Are water heater valves discharging excessively?

- Refer to the section "Water heater valves discharging excessively".

HIGH ELECTRICITY BILLS

If you think your electricity bill is too high, investigate the following:

- You may be using more hot water than you think. This applies especially to showering. Review hot water usage, especially the time taken for showering, and investigate the use of flow control valves or 'water saving' shower roses. Investigate recent changes to hot water usage patterns.
- Water heater valves may be discharging excessively. Refer to the section "Water heater valves discharging excessively".
- There may be hot water leakages in hot water pipes or taps. Have these checked and rectified by a plumber.
- There may have been changes in electricity tariffs since your last bill.

If, after investigating the above, you still require assistance contact Rinnai.

SERVICING AND REPAIR

WATER HEATER VALVES DISCHARGING EXCESSIVELY

Pressure and Temperature Relief (P&TR) valve

It is normal and desirable that this valve allows a small quantity of water to be discharged during the heating cycle. If it discharges more than a bucket of water during a 24 hour period or discharges continuously there may be another problem.

If the valve dribbles continuously, try easing the valve gear for a few seconds as described under 'Regular Care'. This may dislodge any foreign matter and alleviate the problem.

If the valve discharges at high flows, especially at night, it may be as a result of the water pressure exceeding the design pressure of the water heater. Ask your installer to fit a Pressure Limiting Valve (PLV).



- **Never replace the P&TR valve with one which has a higher pressure rating than is specified for your water heater.**
- **If the valve discharges hot water at high flows until the water heater is cold and then stops discharging until the water reheats there may be a serious problem. Switch off the power supply in the meter box (the switch marked 'WATER HEATER' or 'HOT WATER') or the isolating switch installed near the water heater and contact Rinnai.**

Expansion Control Valve (ECV) - if fitted

It is normal and desirable that this valve allows a small quantity of water to be discharged during the heating cycle. If it discharges more than a bucket of water during a 24 hour period or discharges continuously there may be another problem.

If the valve leaks continuously, try easing the valve gear for a few seconds as described under 'Regular Care'. This may dislodge any foreign matter and alleviate the problem. If this does not alleviate the problem contact Rinnai.

SERVICE

The system should be checked and serviced by an authorised person at least every 5 years. The P&TR valve must be replaced at intervals not exceeding five (5) years.

Rinnai has a service and spare parts network with personnel who are trained and equipped to give the best service on Rinnai appliances.

GENERAL INSTALLATION

This appliance shall be installed in accordance with:

- **Manufacturer's Installation Instructions**
- **AS/NZS 3500.4**
- **AS/NZS 3000 Wiring Rules**
- **Local Plumbing, Water and Electrical Authority Regulations**
- **Municipal Building Codes**
- **Any other relevant Statutory Regulations**

THIS APPLIANCE IS NOT SUITABLE FOR USE AS A DOMESTIC SPA POOL OR SWIMMING POOL HEATER.

INSTALLATION DIAGRAMS

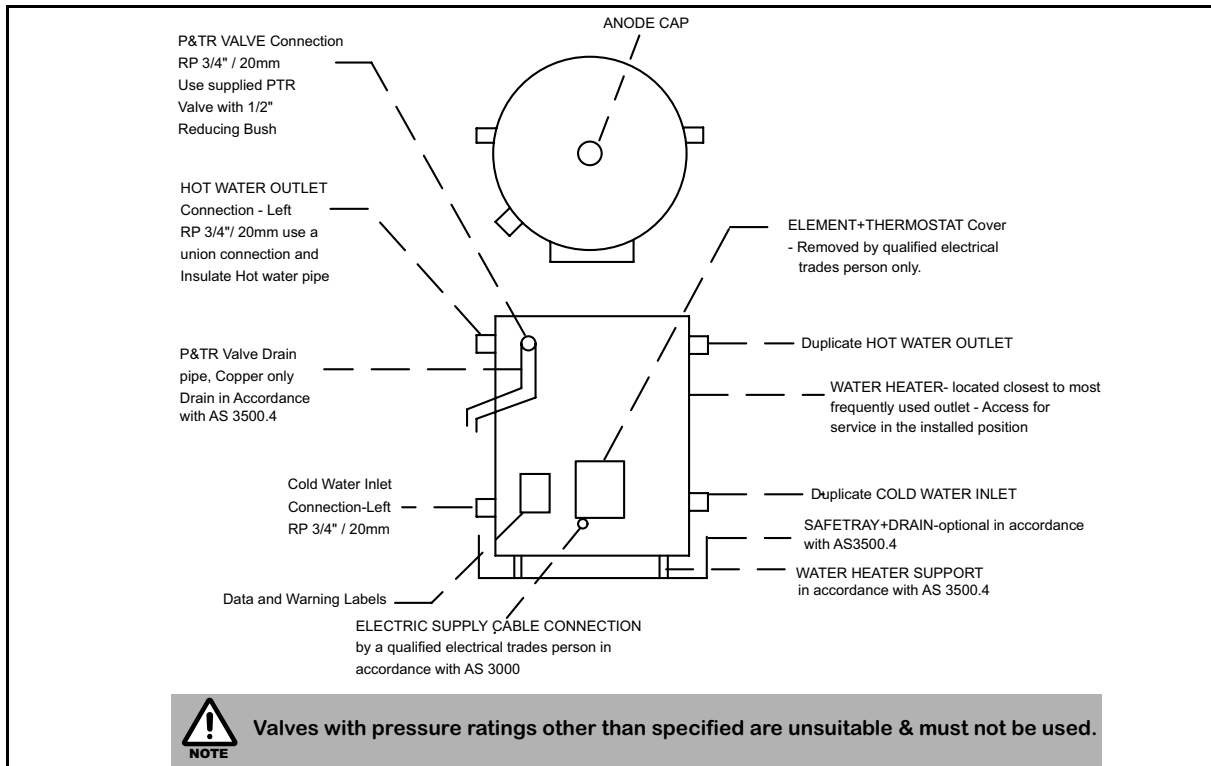

Figure 1 - Typical Installation of Water Heater

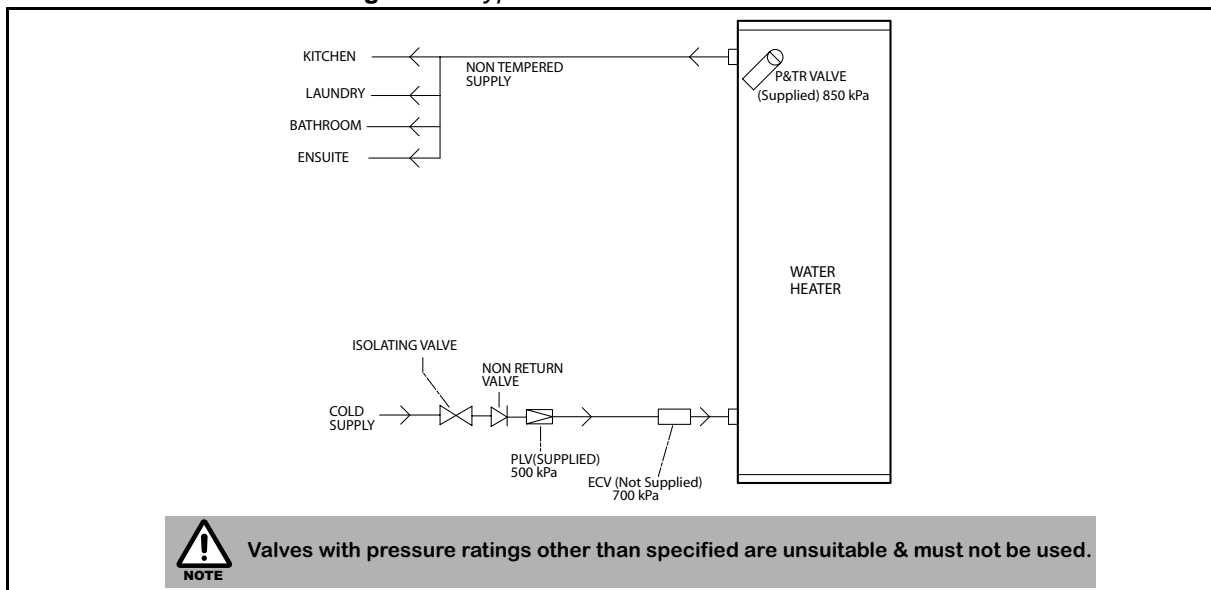
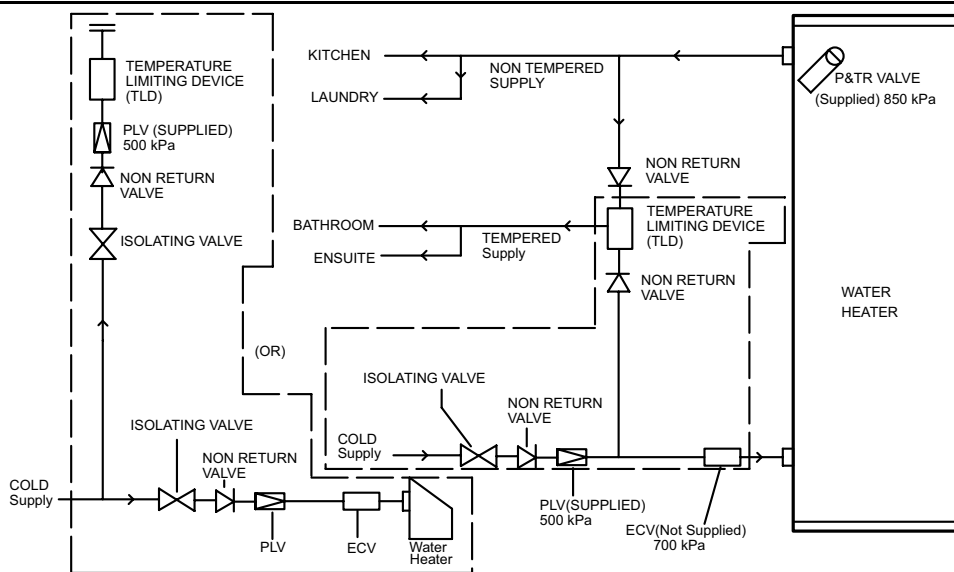

Figure 2 - Hot Water Plumbing System Example - No Temperature Limiting Device

GENERAL INSTALLATION



Valves with pressure ratings other than specified are unsuitable & must not be used.

It may be a requirement that the hot and cold water supply pressures to a Temperature Limiting Device (TLD) are equal. If this is the case, a Pressure Limiting Valve (PLV) with the same pressure rating as the PLV for the hot water is required for the TLD as shown.

Figure 3 - Hot Water Plumbing System Example - with Temperature Limiting Device (TLD)

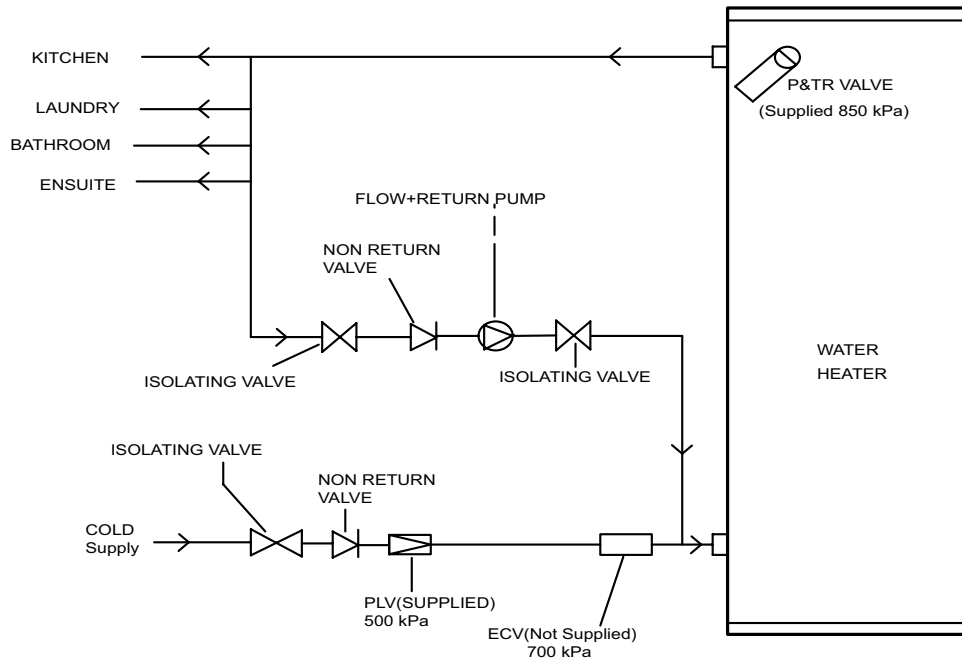

Valves with pressure ratings other than specified are unsuitable & must not be used.

Figure 4 - Hot Water Plumbing Water Heater system Example - with Flow & Return Pipe Work

GENERAL INSTALLATION

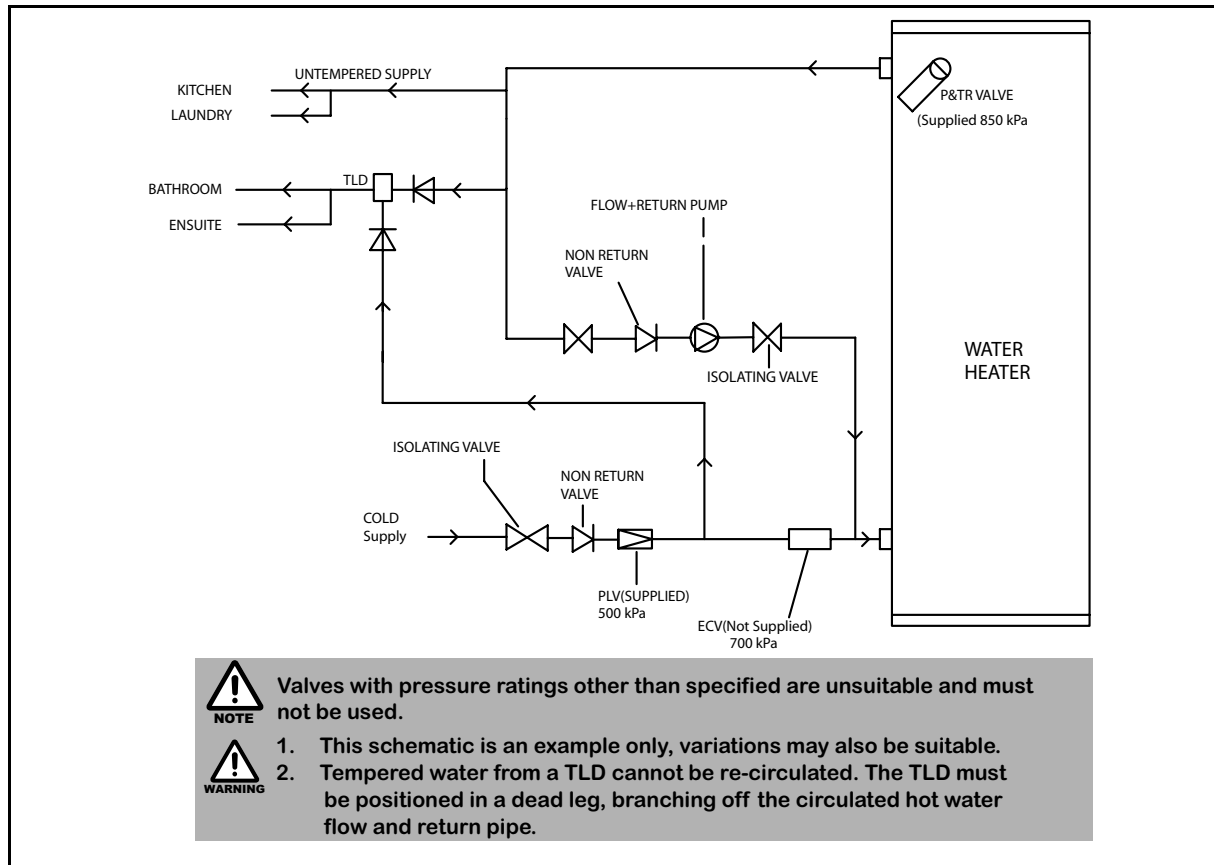

Figure 5 - Hot Water Plumbing System Example with Flow and Return Pipe Work and TLD

WATER HEATER LOCATION

All Rinnai mains pressure electric storage hot water systems have an ingress protection rating of IPX4 making them suitable for internal or external installation.

The water heater should be placed as close as practicable to the most frequently used hot water outlet point or points to minimize the delay time for hot water delivery. This will usually be the kitchen tap. For installations where the distance between the water heater and the outlets is considerable, a flow and return system can be used which minimize the waiting time for hot water delivery.

It is recommended that the water heater is installed at ground or floor level. It must be installed in a vertically upright position. The water heater must be accessible without the use of a ladder or scaffold. It must not be installed in roof spaces.

Ensure the pressure and temperature pressure relief (P&TR) valve, front covers, thermostats and heating elements have sufficient clearances and are accessible for service and removal. The information on the rating plates must also be readable. Leave adequate distance above the water heater (preferably the height of the water heater itself) so the sacrificial anode can be inspected and replaced via the top cover.

The water heater must be installed in freestanding mode on a level and stable base. For external installations, the water heater should be mounted on a concrete base at least 50 mm thick or on well seasoned, evenly spread hardwood slats with a thickness of at least 25 mm. Where property damage can occur as a result of water leakage, the water heater must be installed with a safe tray (overflow tray) and drain in accordance with AS 3500.4. Ensure the water heater does not stand on wet surfaces.

GENERAL INSTALLATION

WATER QUALITY

The water quality of most public supplies is suitable for the water heater. Water quality from bore wells is generally unsuitable. Refer to the 'Warranty Conditions' for water quality parameters and how they affect warranty. If in doubt about water quality, have it checked against the parameters listed in the warranty conditions.

In a scaling water supply, calcium carbonate and possibly other compounds are deposited out of the water onto any hot metallic surface and form a scale.

Scaling water is defined as having a total hardness in excess of 200 mg/litre (expressed as Calcium Carbonate) or a Saturation Index in excess of +0.4. Scale deposits may form onto the metallic surfaces of the P&TR valve and may prevent it from operating properly. To prevent this, an expansion control valve (ECV) must be fitted on the cold water line after the non-return valve in areas of scaling water. ECVs must be fitted in South Australia and Western Australia to comply with local regulations.

Refer to the 'Warranty Conditions' for water quality parameters and how they affect warranty. If in doubt about water quality, have it checked against the parameters listed in the warranty conditions. If sludge or foreign matter is present in the water supply, a suitable strainer or filter should be incorporated in the water supply to the storage cylinder.

Connection to a low pressure gravity or tank water supply

If the water heater is supplied by a low pressure gravity or tank water supply, the bottom of the supply tank must be at least one meter above the highest hot water outlet and care must be taken to avoid air locks. Pipe sizing and valve selection must be performed to allow for the water supply pressure.

HOT WATER STORAGE AND DELIVERY TEMPERATURES

Storage Temperature

AS 3500.4 conveys that hot water shall be stored at a minimum temperature of 60°C. The thermostat setting on the storage water heater has been factory pre-set to 65°C to meet this requirement. The thermostat temperature setting is adjustable to a maximum temperature setting of 75°C but this usually is not required.



- **The thermostat settings must only be adjusted by an Electrician or other suitably qualified trades person.**
- **The access cover to the element and thermostat must only be removed by an Electrician or other suitably qualified trades person.**

Sanitary Fixtures Delivery Temperature

Water temperatures over 50°C can cause severe scalds. Children, disabled and the elderly are at the highest risk of being scalded.

Local regulations and/or the requirements of AS/NZS 3500.4 must be considered regarding the temperature limitations of hot water supplied to areas used primarily for personal hygiene. The temperature of is limited to 45°C for early childhood centres primary and secondary schools and nursing homes or similar facilities for young, aged, sick or people with disabilities and 50°C for all other buildings. To comply with these requirements, a temperature limiting device, such as a tempering or thermostatic mixing valve, will be required on all 'new' installations.

Installers should explain to customers the merits of limiting the temperature of water supplied to areas used primarily for personal hygiene for installations which are not classified as 'new'.

Figures 3 and 5 show the installation examples with Temperature Limiting Devices (TLD's).

Water Pipes

All hot water pipe work should be insulated with Polythene foam or equivalent insulation to optimize performance and energy efficiency. Such insulation may also be mandatory under local regulations. Insulation must be weatherproof and UV resistant if exposed.

Water pipe sizing should be performed in accordance with AS/NZS 3500.4.

To prevent damage to the water heater when attaching pipe clips or saddles to the jacket, it is recommended that self drilling screws with a maximum length of 12mm are used. If drilling is required take extreme care not to penetrate the inner cylinder. Damage to the inner cylinder is **not** covered under warranty.

GENERAL INSTALLATION

Electrical Supply



Electrical connection must be carried out by a qualified person and in accordance with AS 3000 'Wiring Rules' and local authority requirements.

A water heater **not** fitted with a power cord & plug must have the heating element connected to an independent, fused, AC 240V 50 Hz power supply with an isolating switch installed at the switch board. Ensure the household wiring to the system is capable of withstanding the system electrical load (refer to Specifications - **Table 1** for electrical load details). A power cord is available for replacement. Please contact Rinnai Customer Care for part number.

A water heater fitted with a power cord & plug must be plugged into a switched, AC 240V AC, 50 Hz mains power outlet rated at 10 Amps.

The power supply can be Off-Peak (overnight), Extended Off-Peak (overnight and day), or Continuous (day). Check the available tariffs with the local electricity supplier. The Off-Peak (overnight) supply is usually the most economical for the customer.

Valves and fittings

Valves & fittings supplied with water heater are placed in the Styrofoam packaging base during transit.

The pressure ratings of valves are shown in **Table 1**.

The following valves and fittings are supplied:

- A combined Pressure & Temperature (P&TR) Relief Valve. This valve is fitted at the top of the storage cylinder. The P&TR valve is a safety device and it is mandatory that it is fitted by the installer in all installations.
- A Pressure Limiting Valve (PLV). A 500 kPa PLV is supplied with all tanks. It must be fitted if the Mains Pressure exceeds the limits shown in **Table 1**. If the mains pressure is within the limits shown in Table 1 fitment of the PLV is optional. However, it is recommended that the PLV is fitted in all installations as it aids water and energy conservation.
- Two brass plugs are supplied to plug the unused hot and cold connections.
- A reducing bush is supplied to enable fitment of the ¾" P&TR valve connection to the ½" tank connection.

The following valves and fittings are to be supplied by the installer:

- A cold water Expansion Control Valve (ECV) must be fitted in areas with a 'scaling' water supply, having a total hardness in excess of 200 mg/litre (expressed as Calcium Carbonate) or Saturation Index in excess of + 0.4 as detailed under Water Quality, if required. ECVs' must be fitted in South Australia and Western Australia to comply with local regulations. For pressure setting information refer **Table 1**.
- A stop cock and non return valve. Combination valves incorporating these functions (such as 'Duo' or 'Trio' valves) are suitable. These are fitted to the cold water supply to the water heater.
- A pressure limiting device, such as a tempering valve, if required.



Valves with pressure ratings other than those listed above must not be used.

PLUMBING CONNECTIONS

Refer to **Figure 1** for the location and specification of each plumbing connection to the water heater.

The water heater has 'dual handed' cold supply and hot outlet connections. The brass plugs (supplied) are used to plug unused connections.

P&TR Valve Connection

The P&TR Valve must be fitted before the water heater is operated. Before installation, ascertain that the probe is straight and undamaged. Seal the thread with Teflon tape - never use hemp.

Make certain the edge of the Teflon tape does not protrude past the end of the thread. Screw the reducing bush supplied into the fitting on the water heater marked P&TR Valve, then screw the P&TR

GENERAL INSTALLATION

Expansion Control Valve (ECV)

The expansion control valve (if used) must always be installed after the non return valve and be the last valve installed before the water heater (Refer to **Figures 2 - 5**).

Drain Lines

Copper drain lines ($\frac{1}{2}$ " or DN15) must be fitted to the P&TR valve and ECV (if fitted). The length should be as short as possible on a continuous downward slope with no restrictions. Length should not exceed 9 metres with no more than three right angle bends. In areas where water pipes are prone to freezing, drain lines must be insulated and not exceed 300mm in length. In this case the drain line must discharge into a tundish through an air gap of between 75mm and 150 mm.

The outlet of drain lines must be positioned so that they are readily visible but not cause injury, damage or nuisance.

ELECTRICAL CONNECTIONS



The water heater must be filled with water prior to connection to the power supply.



Disconnect all power prior to installation and commissioning. This appliance is designed for single phase 240 Volts, AC mains electrical operation. All electrical connections must be made by an authorised person and must comply with all local electrical supply regulations and AS 3000.



The household wiring to the heater must be capable of withstanding the appliance load.

Electrical access is via a 20 mm hole beneath the element cover for mounting with an approved weatherproof electrical conduit nipple. For entry to the element cover remove the two fixing screws. Connect all ACTIVE and NEUTRAL wires in accordance with the wiring diagram which is also included at the rear of the element access cover. Ensure the incoming EARTH wire is securely fixed to the earth post provided on the heater case. Inspect and ensure that all wiring links are secure prior to fixing the access cover and turning the POWER ON.

To ensure the Over-temperature and Energy Cutout is set, press the (red) 'reset' button on the Thermostat.

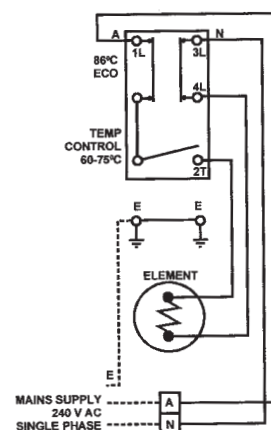

Figure 6 - Single Element Wiring Diagram

Thermostat Setting

The thermostat is adjustable from 60°C to 75°C. Turning the adjustment knob anticlockwise decreases the temperature setting and turning it clockwise increases the temperature setting. Rinnai advice that the thermostat be set at 65° C, this temperature is sufficient for most users. **Ensure the power supply is switched OFF before removing the access cover to the element & thermostat.**



- The access cover to the element and thermostat must only be removed by an Electrician or other suitably qualified trades person.
- The thermostat setting must only be adjusted by an electrician or other suitably qualified trades person.
- After adjustment, press the (red) 'Reset' Button on the thermostats to ensure the over-temperature and energy cut-out is set.

COMMISSIONING

Commissioning and draining activities must be carried out by an authorised person.

To fill and turn 'ON' the water heater



- Do not switch on the electric power supply until the water heater is filled completely with water.

- Open all hot water taps in the house, including the shower.
- Open the cold water isolation valve to water heater. Air will now be forced out of the taps.
- Close each tap when water runs freely without air bubbles.
- Check all plumbing connections and pipe work for water leaks.
- Switch on the electric power supply.

To turn 'OFF' the water heater

It may be necessary to turn off a water heater after installation and commissioning, for example during building activities or if the premises are vacant.

To turn 'OFF' the water heater:

- Switch off the electricity supply at the isolating switch to the water heater.
- Unplug the power supply cord from the power outlet (only for models fitted with power supply cord).
- Close the cold water isolation valve at the inlet to the water heater.

Draining

To drain the water heater:

- Turn off the water heater.
- Close all hot water taps.
- Operate the P&TR valve release - gently. Operating the P&TR valve release will relieve the pressure in the water heater.
- Undo the cold water inlet union. Attach a hose to the water heater side of the union. Let the other end of the hose go to a drain.
- Operate the P&TR valve again. This allows air into the water heater and will result in water draining through the hose.

SPECIFICATIONS

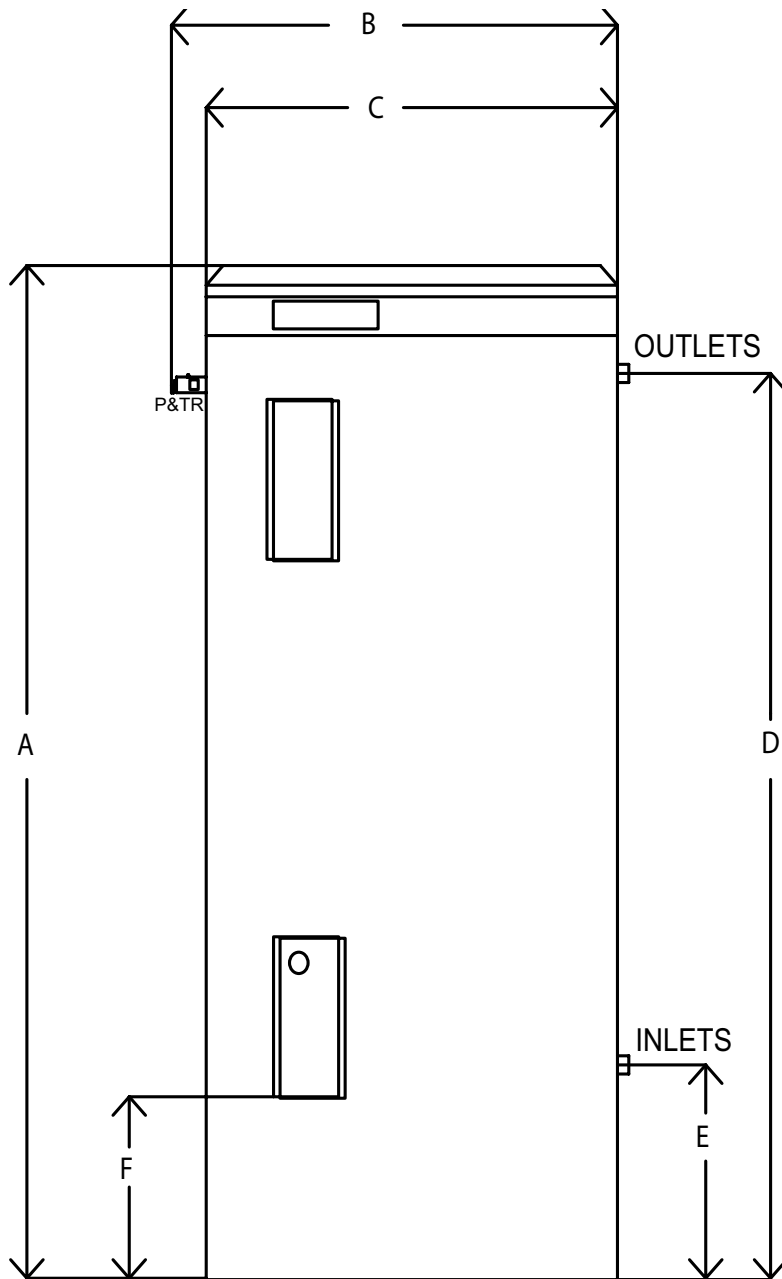

Models	A	B	C	D	E	F
HFE40S	665	470	395	470	75	125
HFE80S	900	590	515	683	225	155
HFE125S	1245	590	515	1020	225	155
HFE160S	1530	590	515	1310	225	155
HFE200S	1825	590	515	1605	225	155
HFE250S	1265	760	685	985	260	155
HFE315S	1510	760	685	1200	260	155
HFE400S	1820	760	685	1512	260	155

Figure 7 - Dimensional Drawing

SPECIFICATIONS

Model Numbers	HFE40S18 HFE40S24 HFE40S36 HFE40S48	HFE80S18 HFE80S24 HFE80S36 HFE80S48	HFE125S18 HFE125S24 HFE125S36 HFE125S48	HFE160S18 HFE160S24 HFE160S36 HFE160S48	HFE200S24 HFE200S36 HFE200S48	HFE250S36 HFE250S48	HFE315S36 HFE315S48	HFE400S36 HFE400S48
Rated Capacity	40	80	125	160	200	250	315	400
Heating Elements Available Watts (W)	1800 2400 3600 4800	1800 2400 3600 4800	1800 2400 3600 4800	1800 2400 3600 4800	2400 3600 4800	3600 4800	3600 4800	3600 4800
Tank Rated Pressure (kPa)	1000					850		
P & TR Valve Pressure rating (kPa)	1000					850		
Expansion Control Valve (ECV) Pressure Rating (kPa)	850					700		
ECV Fitted								
Fit Pressure Limiting Valve (PLV) if mains pressure exceeds: (kPa)	680					550		
Recommended Pressure Limiting Valve (PLV) Pressure Rating (kPa)	500 (1)					500 (1)		
ECV NOT Fitted								
Fit Pressure Limiting Valve (PLV) if mains pressure exceeds: (kPa)	800					680		
Recommended Pressure Limiting Valve (PLV) Pressuring Rating (kPa)	500 (1)					500 (1)		
Thermostat setting (Max)	75° C							
Hot & cold water connections	3/4" (20 mm)							
Ingress Protection Rating (AS 1939)	IPX4							
Note (1) - A 500 kPa PLV is supplied with all tanks. It must be fitted if the Mains Pressure exceeds the limits shown. If the mains pressure is within the limits shown fitment of the PLV is optional. However, it is recommended that the PLV is fitted in all installations as it aids water and energy conservation.								
Electrical power cord length (metres)	1.5							
Legend	HF - Hotflo E - Electric Tank 50 - Rated Capacity of the tank S - Single heating element 24 - First two digits of the Heating element rating eg. 24 = 2400 Watts							

Table 1 - Specifications

WARRANTY

The benefits conferred by this warranty are in addition to all other rights and remedies in respect of the product which you have under the Trade Practices Act and similar State or Territory Laws. Given installation and application is in accordance with the manufacturers specifications and instructions, Rinnai water heaters and components are warranted by Rinnai for the cost of labour and components in the event of defects arising from faulty materials and/or workmanship in accordance with the Terms in **Table 2** and Warranty Conditions and Exclusions stated in this document.

Warranty Terms - Rinnai Hotflo Mains Pressure Vitreous Enamel Storage Electric Water Heaters		
Domestic Applications		
Cylinder	Parts	5 Years
	Labour	3 Years
All Other Parts (Valves etc.)	Parts	1 Year
	Labour	1 Year
Commercial Applications		
Cylinder	Parts	1 Year
	Labour	1 Year
All Other Parts (Valves etc.)	Parts	1 Year
	Labour	1 Year

Table 2 - Warranty Terms

Definition of Domestic Use

The warranty periods that are allocated under "Domestic Use" are based on hot water usage patterns of a typical family.

Rinnai "Domestic Use" warranty periods apply to:

1. Water heaters installed to supply heated water to domestic dwellings.
2. Water heaters when installed to supply heated water to commercial installations such as motel units, hotel rooms, caravans, mobile homes, nursing homes, retirement village complexes and other care institutions and like accommodation provided that maximum preset delivery temperatures for gas boosted models do not exceed 65°C and do not exceed 70°C for electrically boosted models and that the hot water systems are not installed as component(s) of centralised bulk hot water systems and the installation does not incorporate building flow and return systems.

Definition of Commercial Use

The warranty periods that are allocated under "Commercial Use" are for Rinnai water heater(s) installed at premises such as commercial and industrial buildings, cafes, caravan parks and sporting complexes. "Commercial Use" warranty applies to:

1. Water heater(s) supplying central shower blocks.
2. Water heater(s) supplying kitchens used for the bulk preparation of food.
3. Water heater(s) pre-set to exceed 65°C for gas boosted systems and pre-set to exceed 70°C for electric boosted systems.
4. Water heater(s) used in commercial or industrial heating processes.
5. Water heater(s) used in hydronic space heating installations.
6. Any application that uses Rinnai water heater(s) in conjunction with building flow and return systems.
7. Water heater(s) installed as component(s) of centralised bulk hot water system(s).

WARRANTY

WARRANTY CONDITIONS

1. All terms of this warranty are effective from date of installation of the hot water system and the attending service person reserves the right to verify this date by requesting a copy of the certificate of compliance prior to the commencement of any warranty work. Certificates of compliance must be issued by the installer by law in all States and Territories of Australia.
2. All Rinnai water heating components must be installed in accordance with the manufacturers installation instructions, current AS 3000, AS 3500.4 and AS 5601, local regulations and municipal building codes. All Rinnai solar water heating components must only be installed, commissioned and removed by persons authorised by local regulations to do so. All Rinnai solar water heating components must only be serviced and repaired by Rinnai approved technicians.
3. All Rinnai water heaters must be operated and maintained in accordance with manufacturers operating instructions.
4. The warranty applies only to the components supplied by Rinnai. It does not apply to components supplied by others, such as pressure limiting valves, isolating valves, non return valves, electrical switches, pipework, electrical cables and fuses.
5. Where the water heater or it's components have not been sited in accordance with the installation instructions or installed such that normal service access is difficult, a service charge may apply. At the discretion of the attending service person, if access is deemed dangerous service will be refused. Any work required to gain reasonable access to water heater components may also be chargeable at the discretion of the attending service person (for example, removal of cupboards, doors, walls, or the use of special equipment to move components to floor level).
6. Where a failed component is replaced under warranty, the balance of the original appliance warranty will remain effective. The replacement part or appliance does not carry a new warranty.
7. Rinnai reserve the right to transfer functional components from defective appliances if they are suitable.
8. Rinnai reserve the right to have the installed product returned to the factory for inspection.
9. Water chemistry and impurity levels must be within the limits specified in **Table 3**.

Total Dissolved Solids (TDS) mg/litre or ppm	Total Hardness (as CaCO ₃) mg/litre or ppm	Saturation Index (Langelier)	pH	Dissolved CO ₂ mg/litre or ppm
Up to 650	Up to 200	Up to + 0.4 @ 65°C	6.5 to 8.5	Up to 18

Table 3 - Water chemistry and impurity limits for all water heating systems

WARRANTY EXCLUSIONS

The following exclusions apply to all Rinnai water heating systems. They may cause the warranty to become void and may result in a service charge and costs of parts (if required):

1. Accidental damage, acts of God, failure due to misuse, incorrect or unauthorised installations, attempts to repair the heater other than by a Rinnai approved service technician.
2. Where it is found that there is no fault with the water heater and the issue is related to the plumbing installation or is due to the failure of water, electric or gas supplies or corrosive atmosphere.
3. Where the water heater has failed directly or indirectly as a result of excessive water pressure, negative water pressure (partial vacuum) or water pressure pulsation.
4. Subject to any statutory provisions to the contrary, claims for damage to walls, foundations etc. or any other consequential loss either directly or indirectly due to leakage from the water heater or any other faults.
5. This warranty does not cover the effects of sludge and sediment as a result of connection to a water supply from unfiltered sources such as a spring, dam, bore, river, or the entry of sludge and sediment into the water supply for any other reason.
6. Operating the water heater and components when not completely filled with water.

WARRANTY

Please record the following information below for your own records:

Your Retailer : _____

Address : _____

Phone : _____

Purchase Date : _____ Installers License No:: _____

Your Installer : _____ Phone : _____

Address : _____

Installation Date : _____ Cert' of Compliance No : _____

Model No : _____ Serial No : _____

Rinnai

Rinnai Australia Pty. Ltd. ABN 74 005 138 769

Head Office

10-11 Walker Street,
Braeside, Victoria 3195
P.O. Box 460
Tel: (03) 9271 6625
Fax: (03) 9271 6622

Rinnai has a Service and Spare Parts network with personnel who are fully trained and equipped to give the best service on your Rinnai appliance. If your appliance requires service, please call our Hot Water Service Line. Rinnai recommends that this appliance be serviced every 2 years.

Internet: www.rinnai.com.au E-mail: enquiry@rinnai.com.au

National Help Lines

Spare Parts & Technical Info

Tel: 1300 366 388*

Fax: 1300 300 141*

**Cost of a local call Higher from mobile or public phones.*

Hot Water Service Line

Tel: 1800 000 340

BARCODE

U283-931

123 45678 90123 4